

# ***PATHFINDER***

By Dogtra  
GPS Tracking and E-Collar System

## **Owner's Manual**

Please read this manual thoroughly  
before operating the Dogtra Pathfinder.

## Product Safety Information

**⚠ WARNING : Read all safety information below before using your Dogtra product. Failure to follow these safety instructions could result in injury to you, your dog and others, or it could result in damage to your Dogtra product or other property.**

### OWNER SAFETY

#### Handling and Repair

Dogtra products can be damaged or malfunction if dropped, especially on hard surfaces, or otherwise improperly handled. Do not use a damaged or malfunctioning product as it may cause injury or property damage. If your product is damaged or malfunctions, contact Dogtra to obtain service before using the product.

#### Electrical Product

Your Dogtra product contains electrical components and a battery. Do not use or keep Dogtra products near heat or flammable sources as it may damage your product and/or cause fire, explosion, injury, or property damage.

#### Charging

Only charge your Dogtra product with its accompanying Dogtra charger. Do not attempt to charge your product in any other manner or in temperatures less than 32°F (0°C) or over 113°F (45°C) as it may cause fire, explosion, injury, and/or property damage. If you notice damage to your product, its charger, or battery, obtain service from Dogtra before charging the product.

#### Medical Device Interference

Dogtra products contain electrical and magnetic components that emit low level electromagnetic waves and radio frequencies. These electromagnetic waves or radio frequencies may interfere with pacemakers, defibrillators, or other medical devices. Consult your physician or medical device maker before using your medical device with a Dogtra product. If you think that your Dogtra product is interfering with your pacemaker, defibrillator, or other medical device, stop using the Dogtra product.

#### Aggressive Dogs

Do not use Dogtra products with aggressive dogs as such dogs may react adversely and cause injury to people or other dogs. Seek the assistance of a dog-training specialist or veterinarian when dealing with aggressive dogs.

### Children

Dogtra products are not toys. Adult supervision and close attention are necessary when Dogtra products are used by or near children.

## DOG SAFETY

### Proper Use

Dogtra products should be used to train, educate, monitor, or track dogs. Each dog may have a different tolerance for and reaction to Dogtra products. Closely observe your dog when determining the right level of stimulation, collar fit, and other settings of your Dogtra product.

### Training Methods

Dogtra products may be used with a variety of training methods that provide clear and consistent messages to your dog.

### Fit and Wear

Proper fit and wear of your Dogtra product is important for the comfort of your dog as well as the functioning of your product. Dogtra collars should fit comfortably and not too tightly, so that the collar stays in place and does not move around your dog's neck. Do not leave a collar on your dog for an extended time. Although each dog is different, Dogtra recommends that its collars be used a maximum of 4 to 6 hours at any one time on your dog. A collar that is used for overly long periods or that fits improperly may cause skin irritation or sores on your dog's neck. Regularly check the collar's contact area on your dog's skin. If your dog exhibits skin irritation or sores, stop using the Dogtra product and consult with a veterinarian.

### UNAUTHORIZED USE

Dogtra products should be used only in a safe and responsible manner to train, educate, monitor, or track dogs. Dogtra products are not intended for use in any other manner; they are not intended for use with other animals or with humans; and they are not intended for use in unsafe situations or environments that could lead to death, injury, loss or damage.

### BATTERY

Your Dogtra product contains a battery. Do not attempt to replace the battery yourself. Contact Dogtra or your Dogtra retailer to replace your battery. Dispose of batteries as provided by your local regulations. Do not disassemble, crush, heat, or otherwise alter the battery as it may cause fire, explosion, injury and/or property damage.

# Table of Contents

<b>Package Contents</b> .....	6
<b>Main Features of the Pathfinder</b> .....	7
<b>Overview</b> .....	8
<b>When You Receive the Product</b> .....	10
Charging the Pathfinder .....	10
Turning On the Pathfinder .....	11
Operational Buttons .....	12
About the LED .....	13
<b>GPS Connector Parts</b> .....	14
How to Attach the Belt Clip .....	14
Replacing the Antenna .....	15
Maximizing Range.....	15
<b>GPS Collar Parts</b> .....	15
Test Light .....	15
Replacing the Antenna .....	15
<b>Collar Fitting</b> .....	16
<b>Finding the Right Stimulation</b> .....	16
<b>How to Change the Length of the Contact Points</b> .....	17
<b>Acquiring GPS Signal</b> .....	17
<b>Installing the Pathfinder App</b> .....	18
Compatible Phones .....	18
Downloading the App .....	18
<b>Pairing</b> .....	19
Pairing a Phone to the GPS Connector .....	19
Pairing Additional GPS Collars .....	19
<b>App Features</b> .....	20
Map Tab .....	20
Position Display .....	20
Dog Alerts .....	21
Map Gestures .....	21
Dog Position Display .....	22
Connector Position Display .....	22
My Position .....	22
Dog Status Icons .....	22
Marker and Ruler Menu .....	23

Compass Tab .....	24
E-Collar Tab .....	25
<b>Menu</b> .....	27
Device List .....	27
History Files .....	33
Map Select .....	35
Offline Map .....	36
Geo-fence .....	37
App Settings .....	38
User Guide .....	40
<b>General Maintenance Tips</b> .....	40
<b>Troubleshooting Guide</b> .....	41
<b>FCC Warning</b> .....	42
<b>Warranty and Repair Information</b> .....	43

## Package Contents



GPS Connector



GPS Collar



Battery Charger



Splitter Cable



Owner's Manual



Belt Clip



Test Light



Contact Point  
Extension Washer/  
Adjustment Tool



Non-Stimulation  
Contacts

## Main Features of the Pathfinder



2-Second  
Update Rate



Offline Maps



Tracking Only Mode



Precise and  
Up-to-date Maps



9-Mile Range



Geo-fence Option



Non-Stimulating  
Audible Tone



Nick/Constant  
Stimulation



Enhanced Contact  
Points



Expandable to  
21 Dogs



Fully Waterproof



3.5-Hour Rapid  
Charge Batteries



Low-High Output in  
1-100 Stimulation Levels



Belt Clip

## Overview



**PATHFINDER**  
GPS Connector

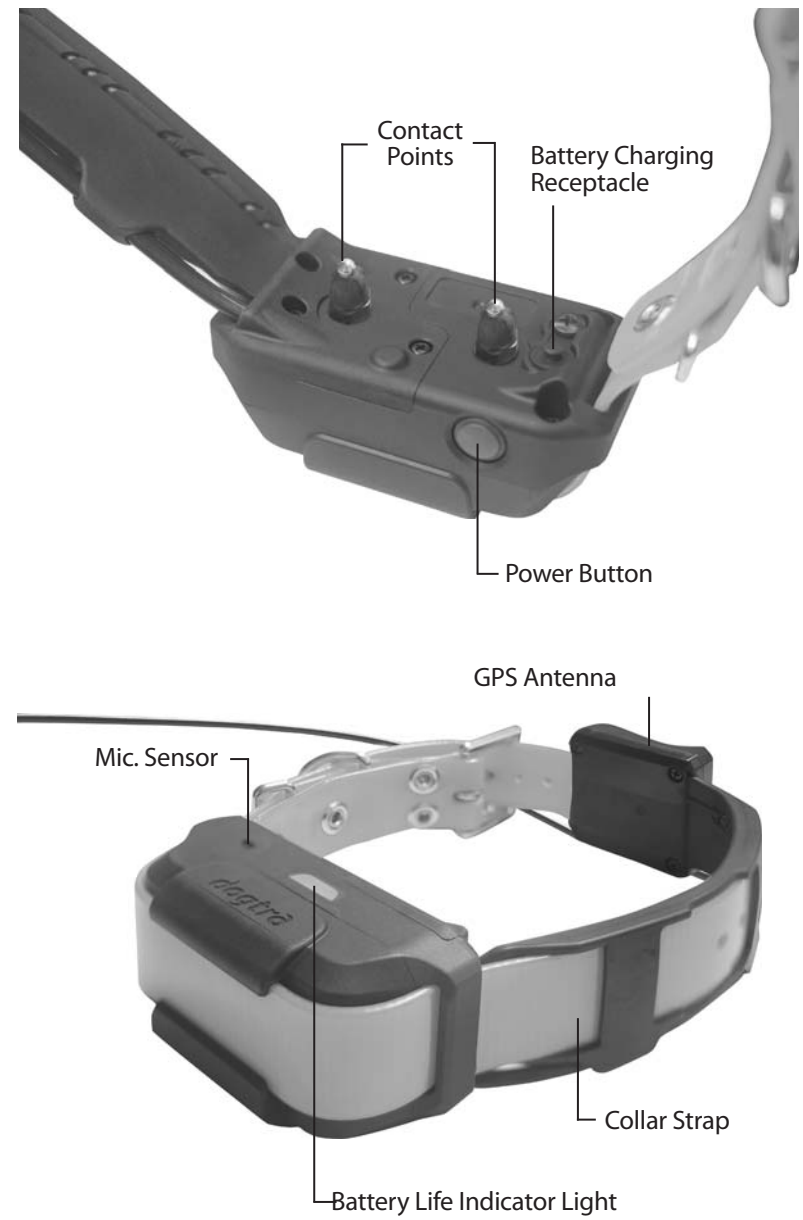

**PATHFINDER**  
GPS Collar

## When You Receive the Product

### Charging the Pathfinder

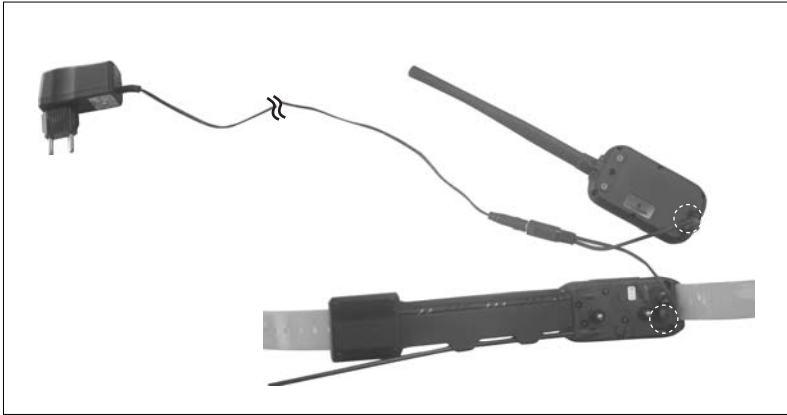

Fully charge the Pathfinder GPS Connector and GPS Collar before the first use. The Pathfinder uses Lithium Polymer batteries.

- Only use official Dogtra chargers with the Pathfinder.
- Do not charge the Pathfinder near flammable substances.
- Fully charge the Pathfinder if storing for 1 month or longer.

### When to Charge

- When the LED is red on the GPS Connector or GPS Collar.
- When the Pathfinder app displays a low battery percentage for the GPS Connector or GPS Collar.
- When the LED does not turn on.

### How to Charge

- 1) Connect the charger to the GPS Connector and GPS Collar using the splitter cable.
- 2) Plug the charger into a 120-volt outlet.
- 3) When fully charged, detach the cables and plug the rubber caps over the charging ports on the GPS Connector and GPS Collar.
- 4) The GPS Collar turns off and cannot be used while charging. The GPS Connector functions while being charged.  
The LED will display red while charging and green when the unit is fully charged. The GPS Connector LED will be green when turned on while charging. A depleted battery requires 3.5 hours to fully charge.

## Turning On the Pathfinder

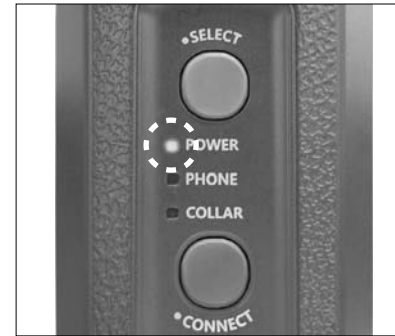

### GPS Connector

- To turn on the GPS Connector, press the blue Select button until the LED turns on.
- To turn off the GPS Connector, press the blue Select button until the red LED turns off.



### GPS Collar

- To turn on the GPS Collar, press the Power button until the LED turns on.
- To turn off the GPS Collar, press the Power button until the LED turns red.
- A tone will be played to indicate that the GPS Collar is turning on or shutting down.

## Operational Buttons



### GPS Connector

The SELECT button is used to turn on/off and select a device to pair. While turned on, press the Select button once to set pairing to the GPS Collar, press the Select button a second time to set pairing to the smartphone app.



The CONNECT button is used to connect the GPS Connector to a Phone and GPS Collar. Press and hold down the Connect button until the LED blinks rapidly. The GPS Connector will now be ready for pairing.

\* Using the Select button, set the GPS Connector to Collar to pair the GPS Connector with the GPS Collar. Setting the GPS Connector to Phone is used to pair the GPS Connector to a phone.



### GPS Collar

**Power On :** To turn the GPS Collar on, press the Power button until the green LED turns on.

**Power Off :** To turn the GPS Collar off, press the power button until the LED turns off.

**Pairing :** To place the GPS Collar into pairing mode, begin with the device turned off and hold down the power button until the LED blinks rapidly. A melody will be played when the GPS Collar is in pairing mode.

\* The GPS Collar pairing mode is used to pair the GPS Collar and the GPS Connector. The Pathfinder set comes with both parts paired to each other.

## About the LED



### GPS Connector

**POWER :** The POWER LED blinks every 2 seconds while turned on. The LED colors, green (~50%), orange (~10%), and red (~0%), represents the battery life.

**PHONE :** Press the Select button twice to set the GPS Connector to Phone. When set to Phone, a green LED will stay on. Holding down the Connect button will place the GPS

Connector into pairing mode and the LED will blink rapidly in green.

**COLLAR :** Press the Select button once to set the GPS Connector to Collar. When set to Collar, a green LED will stay on. Holding down the Connect button will place the GPS Connector into pairing mode and the LED will blink rapidly in green.



### GPS Collar

The LED on the GPS Collar blinks while turned on, and the LED colors green (~50%), orange (~10%), and red (~0%), represents the battery life.

## GPS Connector Parts

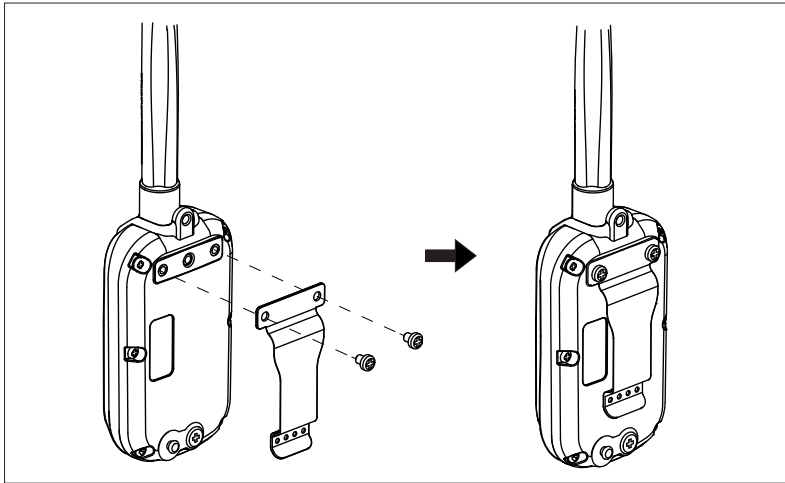

### How to Attach the Belt Clip

- 1) Align the belt clip to the grooves on the back of the GPS Connector.
- 2) With a firm grip, screw on the belt clip using the provided Philips head screws.

**Caution!** Tighten until firmly in place. Be careful not to over tighten.

### Replacing the Antenna

Twist the antenna counter-clockwise to remove.

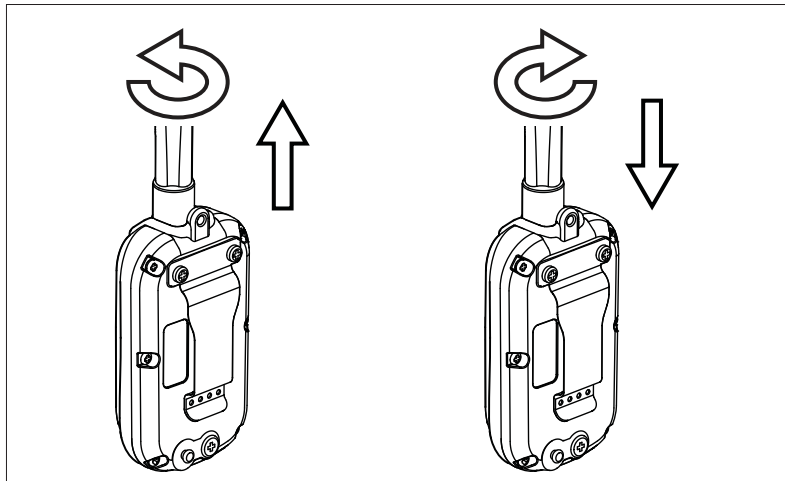

## Maximizing Range

- The Pathfinder has a 9-mile line-of-sight range.
- Holding the GPS Connector high with the antenna facing up will maximize the range.
- Connector device must be near your phone for proper operation. Preferably less than 33ft.

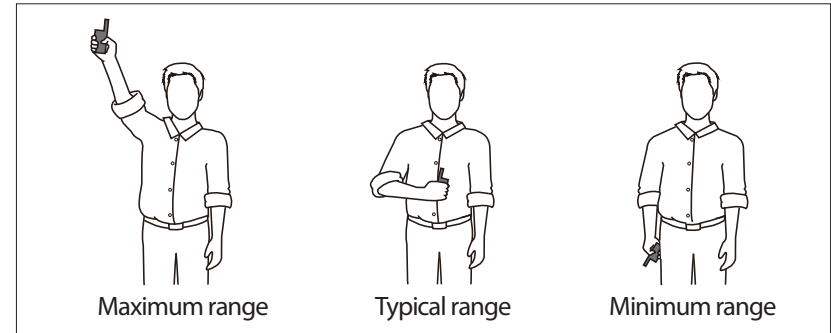

## GPS Collar Parts

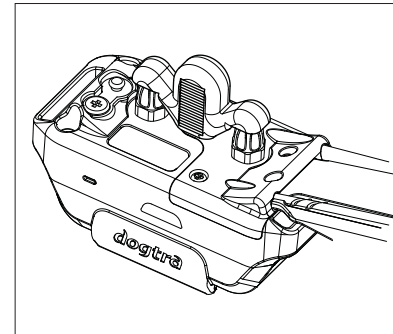

### Test Light

- 1) Turn on the GPS Collar and place the test light over the contact points.
- 2) The test light will illuminate momentarily when the Nick button is pressed in the Pathfinder app. The light will stay lit as long as the Constant button is pressed in the Pathfinder app, up to 12 seconds.
- 3) The test light will emit a brighter light when the stimulation is increased.

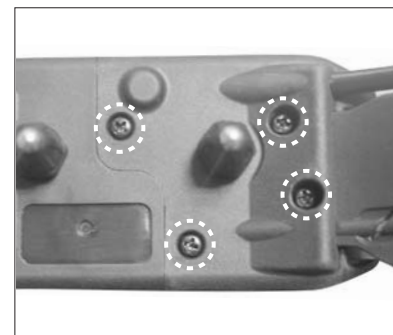

### Replacing the Antenna

Open the antenna enclosure by removing the 4 screws and the contact points. Remove the screw holding the antenna in place to replace the antenna.



## Collar Fitting

The collar should be fitted so that the contact points press firmly against your dog's skin. When properly fitted, you should be able to fit a finger or two snugly in between the contact points and your dog's skin. With a proper fit, the collar should not move on your dog. The best location for the collar box is either side of your dog's windpipe.

A loose fit can allow the collar to move around on your dog's neck. When this happens, the contact points may rub the skin and cause irritation. If the collar is too tight, your dog may have difficulty breathing.

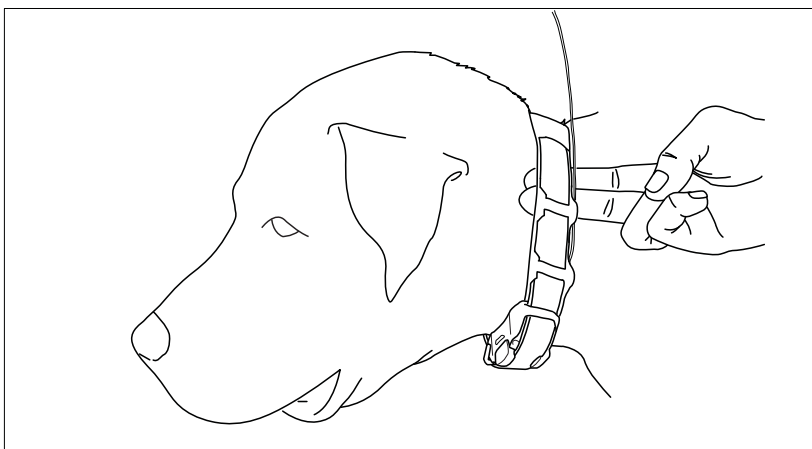

## Finding the Right Stimulation

- Open the Pathfinder app to the E-Collar tab and select your dog and stimulation level.
- The stimulation levels are from 1 (lowest) to 100 (highest).
- Always start at the lowest level of stimulation and work your way up.
- The appropriate level can be found when your dog responds to the stimulation with a mild reaction, such as a tensing of the neck muscles.

Note : Every dog has a different tolerance and reaction to the stimulation. Please look at your dog's reaction to find the right level of stimulation. The stimulation level may vary depending on the situation and distractions. A distracted dog will require a higher level of stimulation compared to when there is no distraction.

## How to Change the Length of the Contact Points

The Dogtra Pathfinder comes equipped with standard 5/8" contact points that can be extended to 3/4" contact points, for use with dogs with longer coats. To increase the contact point length from 5/8" to 3/4", follow the steps below.

- 1) Using the included adjustment tool with the side marked 5/8", unscrew the contact points counter-clockwise.
- 2) Place the contact point extension over the exposed threads, flat side down.
- 3) Place the contact points over the extensions and tighten the contact points and extensions clockwise using the adjustment tool with the side marked 3/4".

\* **Caution** : Tighten until firmly in place. Be careful not to over tighten. To shorten the contact points back to the standard 5/8", start with the adjustment tool with the side marked 3/4", remove the contact point extensions, and tighten the contact points with the adjustment tool with the side marked 5/8".

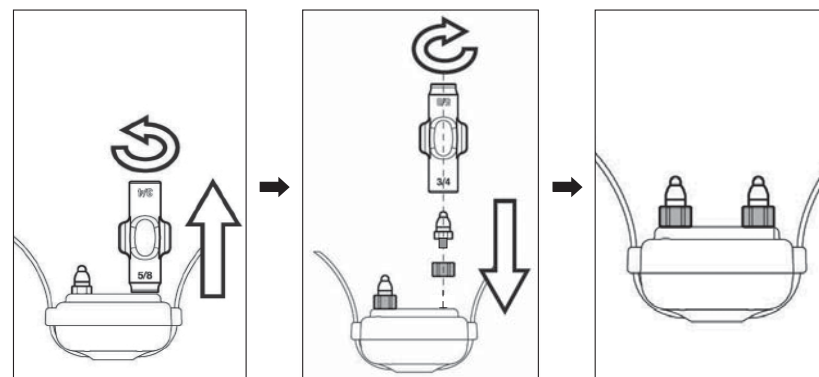

## Acquiring GPS Signal

The Pathfinder is meant for use in open outdoor areas. After pairing, take the GPS Collar outdoors to acquire a GPS signal. Once the signal is acquired, the GPS Collar icon will appear on the Map tab of the Pathfinder app. Operating the Pathfinder near tall buildings and other steel structures will reduce the range of the GPS signal. Not acquiring a GPS signal for prolonged periods of time while outside may indicate issues with the unit.

## Installing the Pathfinder App

### Compatible Phones

- 1) iOS : iOS 8.1 and above  
iPhone 5, 5C, 5S, 6, 6+, 6S, 6S+, 7, 7+  
iPad Generation 3 and above
- 2) Android : Android 4.3 and above  
Samsung Galaxy S4 and above, Note 2 and above, and LG G3

### Downloading the App

Search for Dogtra Pathfinder in the App Store or in Google Play.



iOS App Store

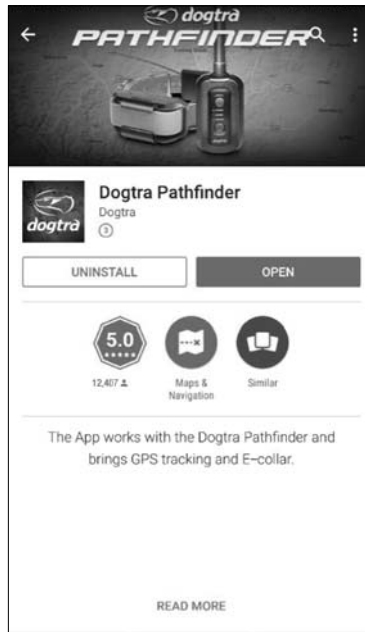

Android Google Play Store

## Pairing

Pathfinder GPS Connector connects between your smartphone and Pathfinder GPS Collar. These devices need to be paired for the Pathfinder system to work properly.

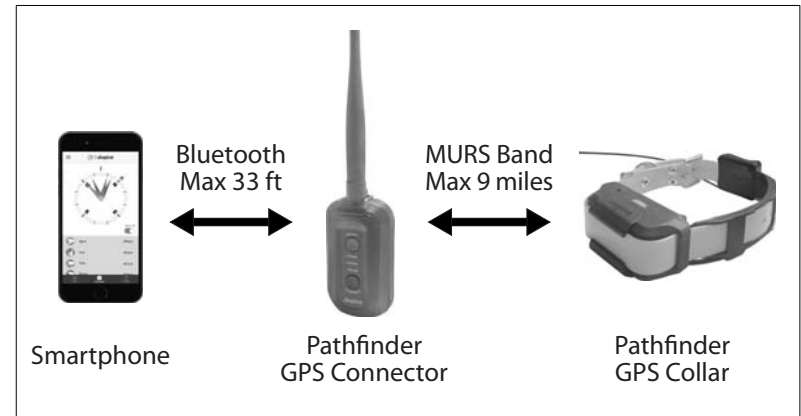

### Pairing a Phone to the GPS Connector

- 1) Launch the Pathfinder app
  - 2) Turn on the GPS Connector
  - 3) In the Pathfinder app, navigate to Menu → Settings → Bluetooth Pairing
  - 4) Set the GPS Connector to pairing mode and click search in the app.
- Once paired, launching the app when the GPS Connector is on will automatically connect them together.
  - The GPS Connector should be within Bluetooth range (33 feet) of your phone to operate.
  - The GPS Connector will reconnect with the phone when it is within range.
  - Reinstalling the app will require pairing with the GPS Connector.
  - The Pathfinder app may need to be restarted for compatibility issues.

### Pairing Additional GPS Collars

Pair the GPS Connector and GPS Collar in close proximity to each other. You can use the Pathfinder app to check if the GPS Collar is properly paired.

- 1) Turn the GPS Connector on.
- 2) Check that the GPS Collar is turned off.
- 3) Use the Select button on the GPS Connector to set the LED to Collar.
- 4) Hold down the Connect button for 5 seconds until the LED blinks rapidly.
- 5) Hold down the Power button on the GPS Collar until the melody is played.
- 6) The melody will stop and the LEDs on the GPS Connector and Collar will return to blinking in normal intervals when pairing is complete.

# App Features

## Map Tab

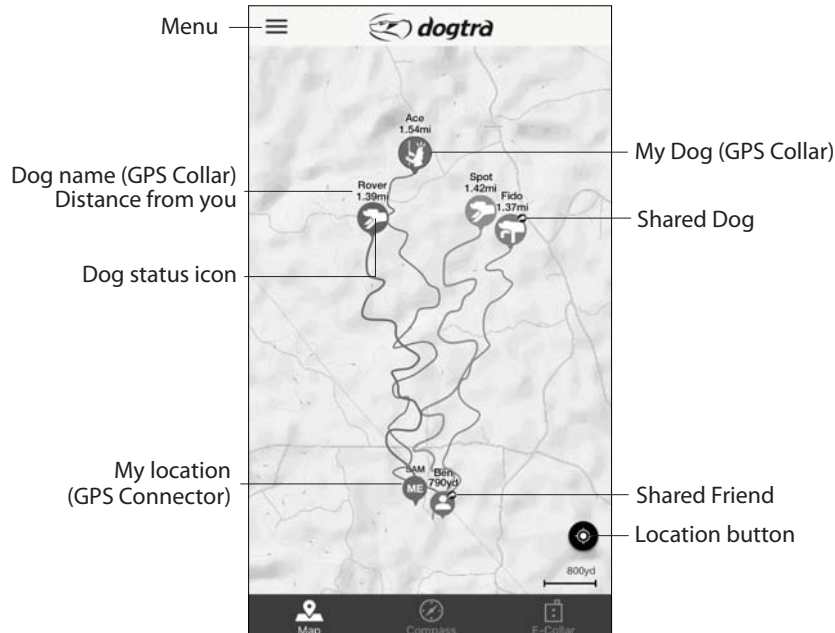

## Position Display

With the GPS Connector paired to a GPS Collar and phone or when receiving shared GPS Connector/Collar devices, their positions will be displayed on the map.

The GPS Collars can be identified by name and color.

The GPS Collar name and color can be edited from Menu/Device List/Device/Edit.

GPS Collars shared with you can be identified by the shared symbol (👤 or 👤) on the icon.

\* Devices that are offline or hidden will not be displayed on the map.

## Dog Alerts

Select a dog on the map to receive notification alerts for that dog. Dog alerts are sent for the selected dog only. The current selected dog is displayed with an outline around their icon.

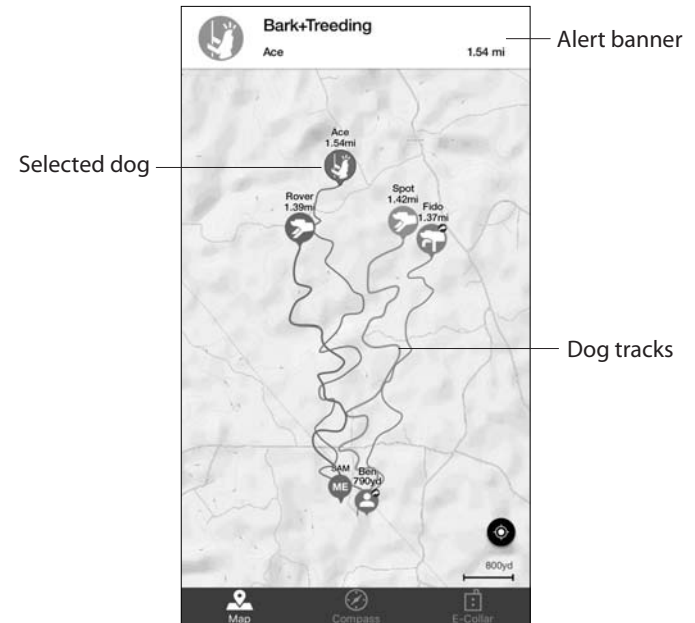

## Map Gestures

The Pathfinder Map tab has multiple map gestures to help make finding your way around easier.

### Zoom

- You can double tap the Map to zoom in by 1 level.
- Use a two finger single tap on the Map to zoom out by 1 level.
- Use two fingers to pinch the screen to zoom in, and stretch the screen to zoom out.
- Zoom in and out using one finger by double tapping and holding down on the second tap, while sliding up and down.

### Scroll

- You can scroll by dragging the map around to the area you want to view.

### Tilt

- Tilt the map by using two fingers and dragging the map up or down.

### Rotate

- Rotate the map by using two fingers and applying a turning motion.

## Dog Position Display

Your dog's location is viewed on the map along with the collar name and distance from your position. The dog icon displays your dog's current action status.

When your dog's action changes, the icon action status will change as well. The dog display icon will change with poor connection, GPS signal loss, or low battery, to an icon that represents these issues. Devices shared will display the shared symbol on the device icon.



## Connector Position Display

See the section on sharing/receiving devices.

When viewing shared GPS Connector devices, an icon (↻ or ↻) will be displayed along with the device name and distance from your position. The shared GPS Connector display icon will change with a poor connection, GPS signal loss, or low battery, to an icon that represents these issues.

## My Position

When the GPS Connector is paired with your phone, your current position and tracks will be displayed.

## Dog Status Icons

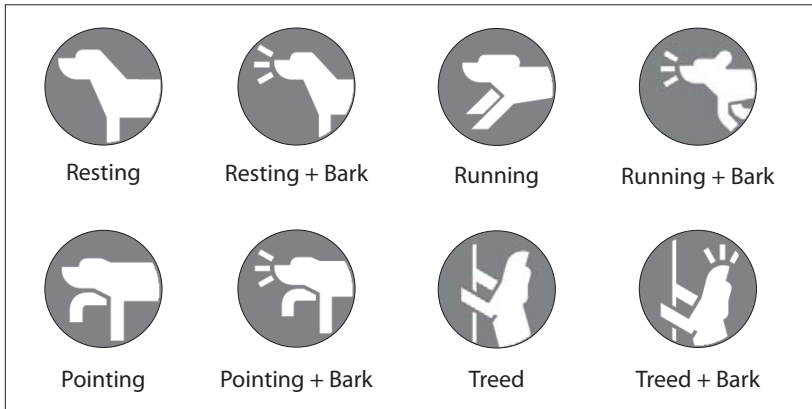

## Marker and Ruler Menu



Marker

Ruler

### Markers

Long pressing anywhere on the map opens up the Marker Ruler Menu. The markers can be used to mark important locations. Markers are also recorded onto history files and removed at the start of a new hunt. Text can be saved along with the markers.

### Ruler

The distance ruler can measure the distance between multiple points. When finished, click "x" to exit out of the distance ruler.

## Compass Tab

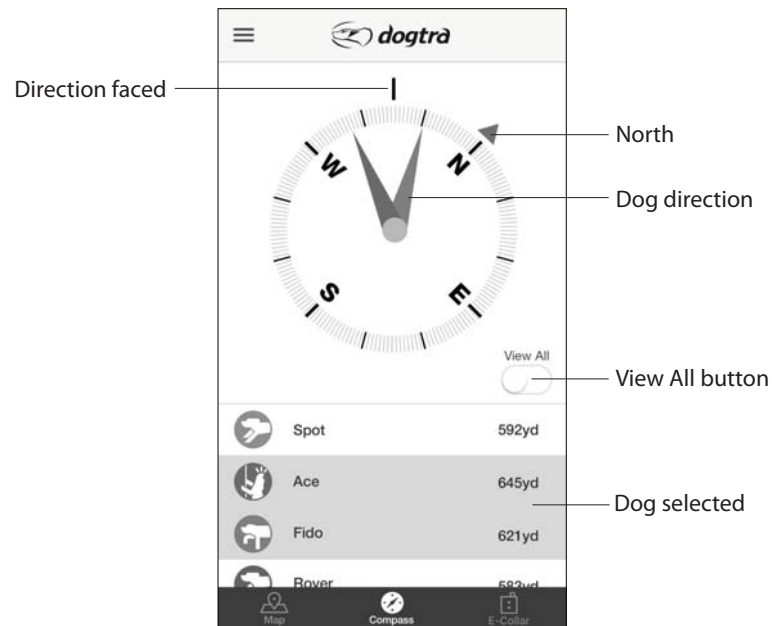

View the direction and distance of dogs and hunters at a glance. Selecting dogs and hunters from the list will display them on the compass. Use the View All button to view all dogs and hunters at once. Dogs and hunters are not displayed when hidden or offline.

- Phone cases made of metal or metal objects attached to the phone will interfere with the compass.
- The phone may need to be calibrated for the compass to work properly.

## E-Collar Tab

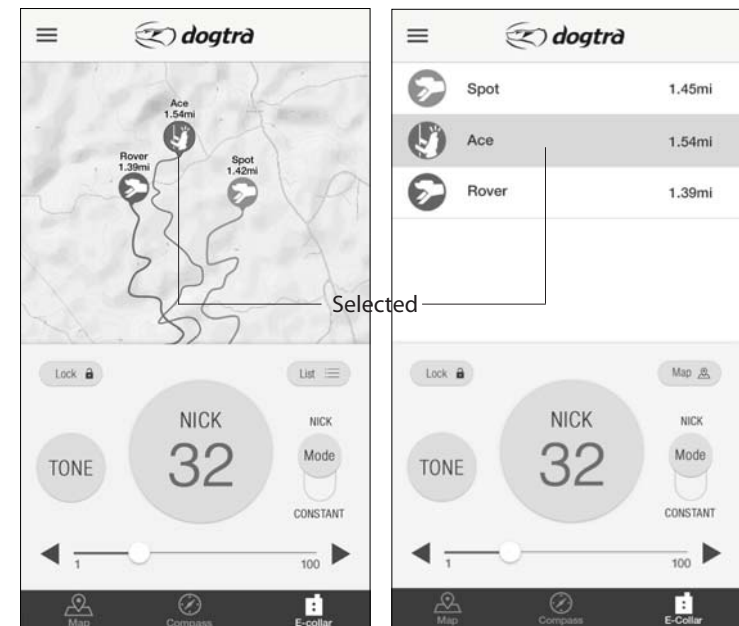

Map View

List View

## Training Functions

Nick or Constant stimulation or an audible Tone can be sent to the selected dog. The tone sound level cannot be adjusted and the tone will ring each time the button is pressed. Nick and Constant stimulation modes have stimulation levels from 1 to 100. The stimulation level is controlled by the stimulation slider and stimulation increase/decrease buttons on the left and right of the slider. The stimulation level can be set for individual dogs.

## E-Collar Buttons

### List/Map View

Dogs can be selected using the dog list or in map view. List view displays dogs in a list along with their distance from you. The list view is recommended when training multiple dogs. Map view displays selectable dog icons on a mini map. The map view is recommended for long distance recall commands.

\* Dogs are not displayed when hidden or offline.



### Mode Button

Use the mode button to switch between Nick and Constant stimulation modes.

### Lock Button

The lock button disables training functions until unlocked.  
Use the lock feature so dogs are not accidentally stimulated.

### Sending Stimulation

- 1) Select a dog from list or map view.
  - 2) Select the stimulation level using the stimulation slider or stimulation increase/decrease buttons.
  - 3) Set the stimulation to Nick or Constant using the mode button.
  - 4) When set to Nick a single 1/4 second burst of stimulation will be applied.  
When set to Constant, stimulation will be sent as long as the button is held down, for up to 12 seconds.
- \* The E-Collar tab is disabled when the Tracking Only mode is turned on in the Settings menu.
  - \* E-Collar feature is disabled for shared dogs.

## Menu Device List

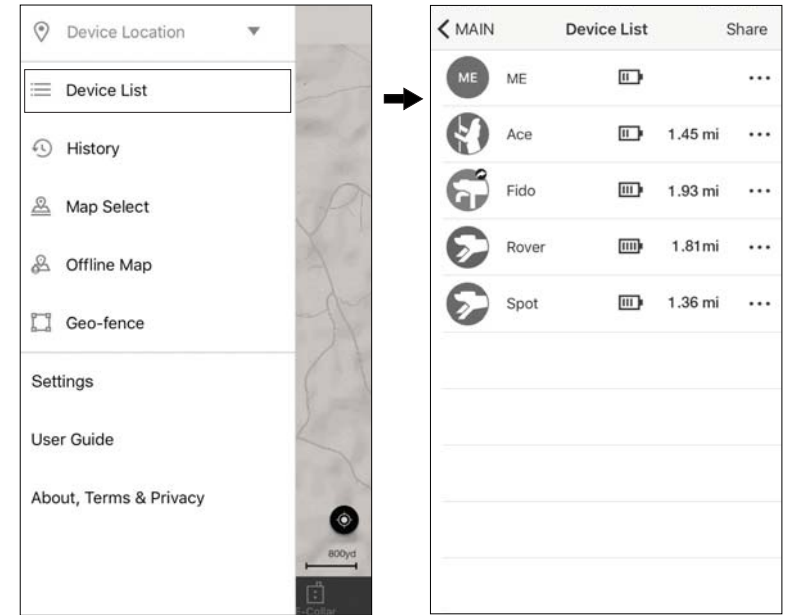

### List of Connected Devices

- Connected devices are displayed in Device List.
- The dog icons display the dog's current action.
- Device battery life and distance from your location is displayed.
- Selecting a device will display detailed information.

## Device Sharing

Press the share button to share and receive GPS Connector/Collar devices. Both sharing and receiving Pathfinder users must use the device sharing feature within close proximity to each other.

### Sharing a Device

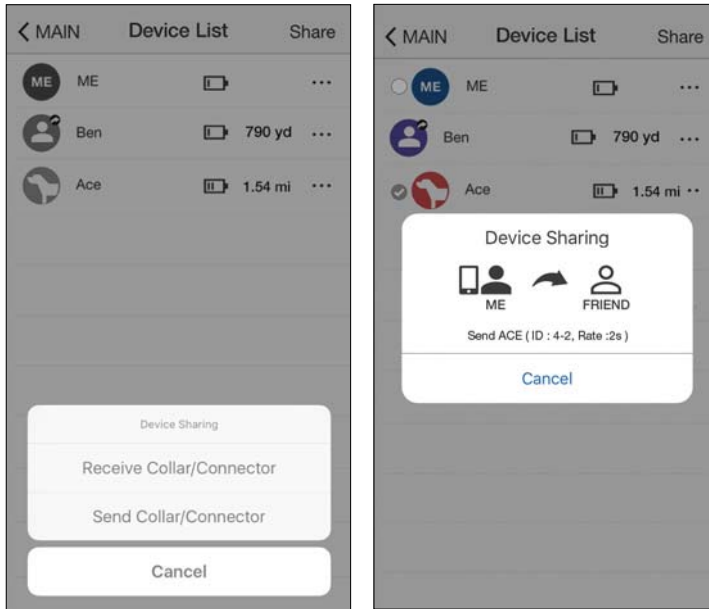

- You can share your position or your dog's position.
- Press the share button and select the device you want to share.
- A pop up will appear when a device has been successfully shared.

### Receiving a Device

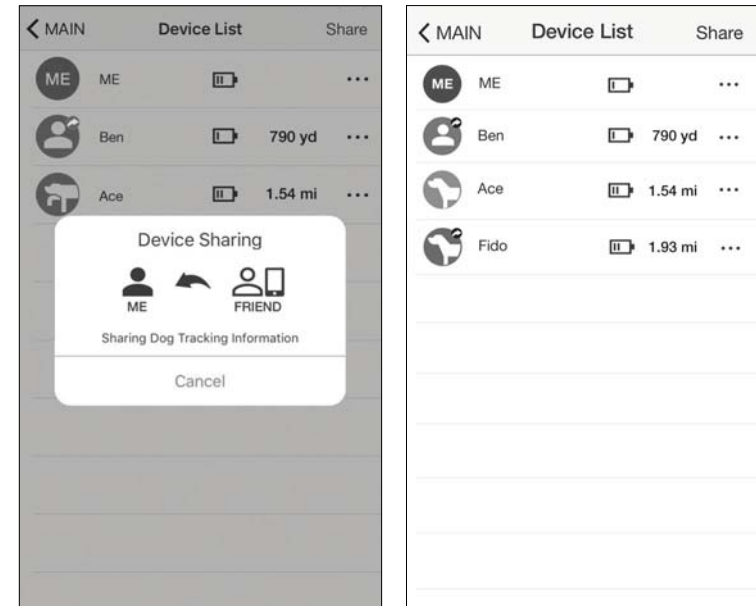

As another Pathfinder user is sending a device, press the share button and receive from the pop up menu. A pop up will appear when a device has been successfully received. Shared devices can be identified by the shared symbol (📶 or 📶) and are displayed on the Map and Compass, along with the tracks and dog statuses as they update.

- E-collar and updating GPS settings are disabled for received shared devices.
- GPS settings are disabled for offline devices.

## Device List Options

Press the more options button (⋮) to bring up the options to hide or reorder devices.

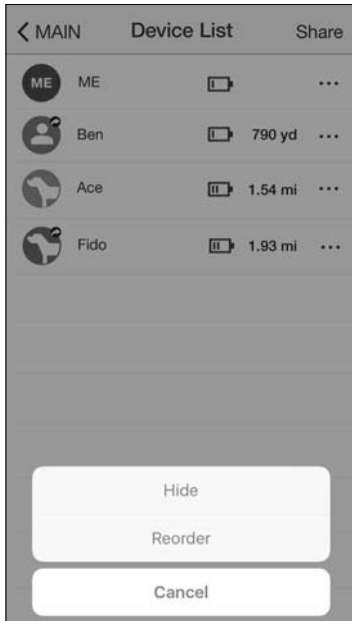

### Hide

Hidden devices do not show up in the map, compass, and e-collar tabs. Use the more options button in the Device List to unhide a device.

### Reorder

Reorder how the devices show in the app. Press reorder to place the device in sorting mode. Hold down the sort button and place the device in the desired position. The new order will be used in the map, compass, and e-collar tabs.

## Device Details

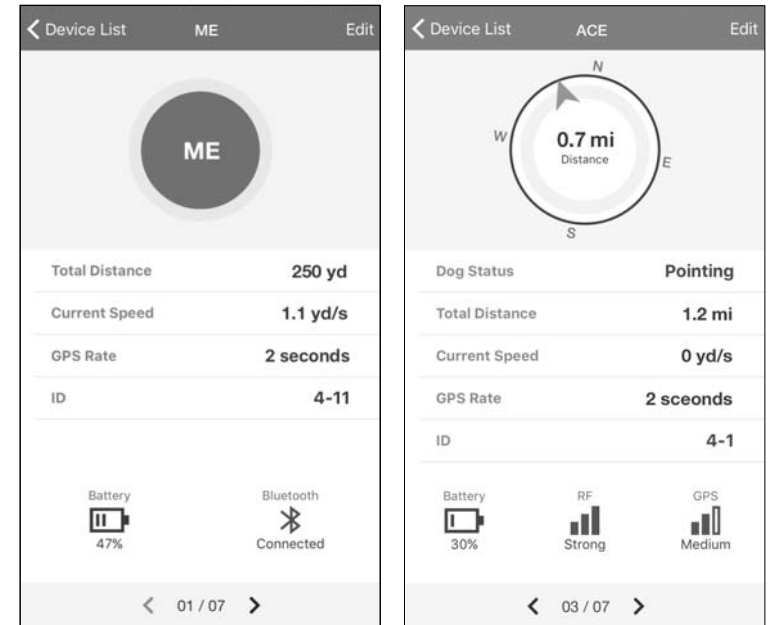

Press a device from the device list to go to the device details page. The device details displays the total distance traveled, current speed, ID, GPS strength, Radio Frequency strength, and battery level, shared and hidden statuses. Slide the device details page to view other devices.



## Device Info Edit

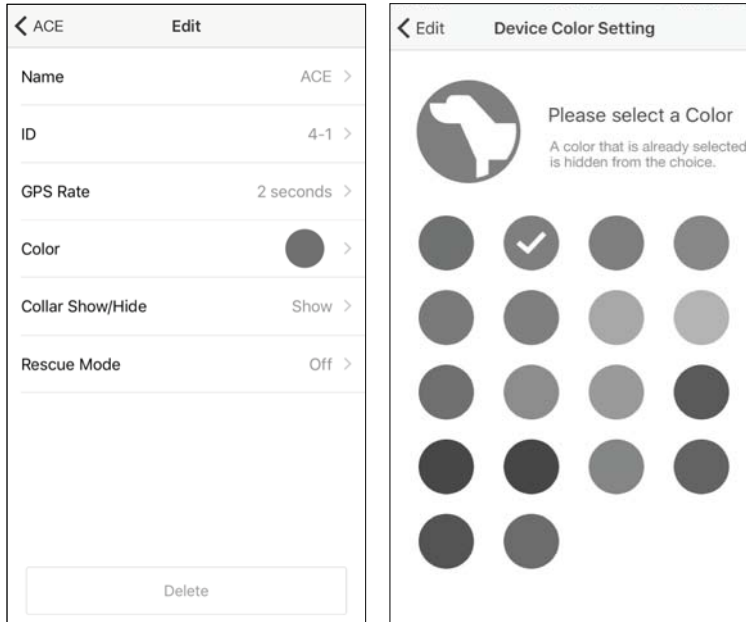

### Edit

Press the edit button to change device settings.

### Name

Press Name to edit the device name.

### ID

The GPS Collar ID can be changed. Change the ID when the signal conflicts with another GPS Collar. The ID of devices that are shared with you cannot be changed. The first number in the ID is the Channel and the second number is the order. Do not use the same ID for additional GPS Collars.

### GPS Rate

The GPS update rate can be changed for each device with options for 2 seconds, 6 seconds, 10 seconds, 30 seconds and 120 seconds. The update rate of devices that are shared with you cannot be changed.

### Color

The color associated with the GPS Collar can be changed. The device color is used in the icon, tracks, compass needle, and in the device list views.

### Collar Show/Hide

Hide or show a hidden device.

## Rescue Mode

Turning on Rescue Mode activates when the GPS Collar battery life is at 25% or less. The device is placed in sleep mode, and the update rate is changed to 120 seconds to reduce power consumption.

The rescue mode setting cannot be changed for devices that are shared with you.

## Delete

Delete removes pairing between the GPS Collar and GPS Connector, or removes from the app devices shared with you. To add back the GPS Collar, the GPS Collar and GPS Connector will have to be paired. Previously shared devices will need to be shared again.

## History Files

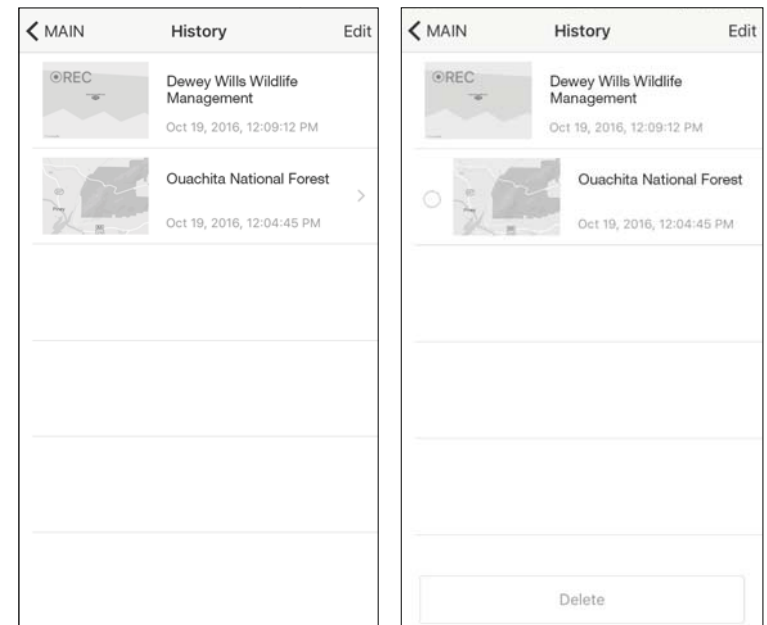

View history files and delete using the edit button. History files currently recording cannot be accessed until completed. Select completed history files to playback and view details. A history file begins recording when the GPS Connector is connected to the phone and the app is open. History files currently recording cannot be accessed until completed. Use the edit button to delete history files.

## History Detail

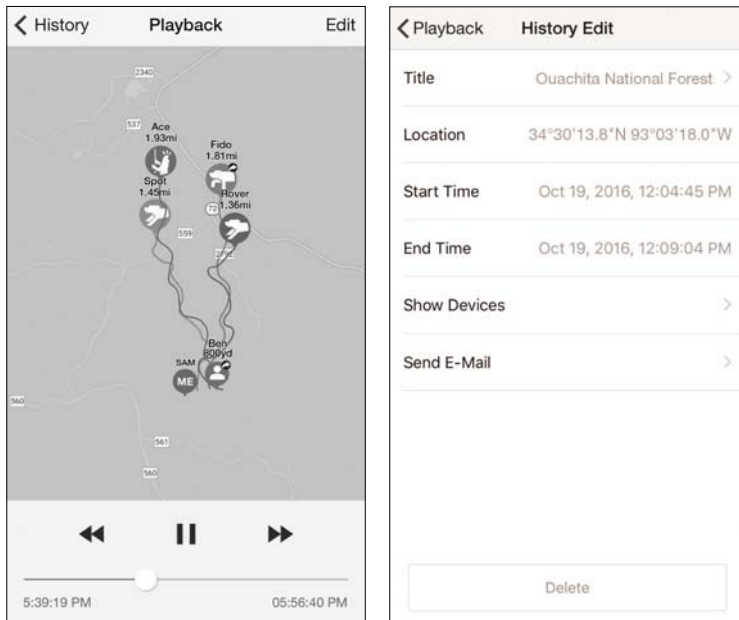

### Play Button

The history file displays the track movement of dogs and people. Use the play button to view the movement from start to finish, or use the slider to jump to a specific time.

### Show Devices

Select/deselect the devices you want to see/hide in the history file Playback.

### Send History File

Completed history files can be emailed as a KML file. iPhone users can download the KML file using iTunes. KML files can be viewed on a desktop computer using Google Earth.

## Map Select

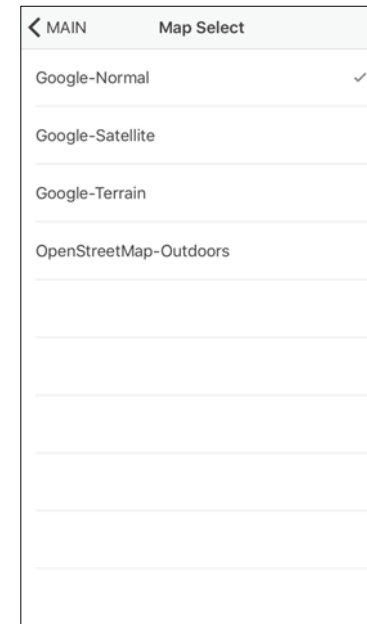

A preferred map view can be selected. Choose between the following options:

- Google Map – Normal
- Google Map – Satellite
- Google Map – Terrain
- OpenStreetMap - Outdoors

## Offline Map

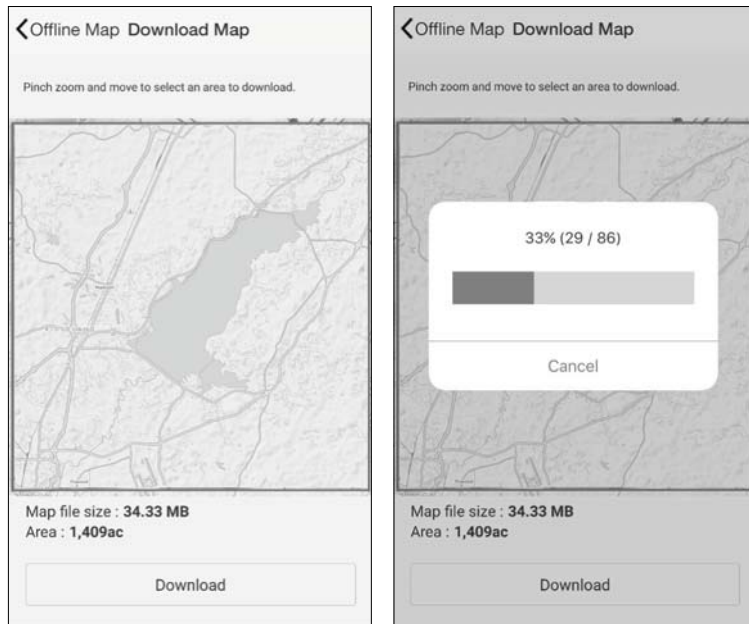

Download offline areas and view areas downloaded for offline use.

### Offline Maps

- View offline map area and details.
- Use the edit button to rename or delete the offline map.
- Downloaded map file size must be less than 200MB.

### Map Download

The offline map is displayed when cellular data/wifi is unavailable. Offline maps should be downloaded before entering areas with limited data. Navigate to the area you wish to download and use pinch and zoom to specify the area. To use the offline map, you must select Offline-Outdoors from the Map Select menu.

## Geo-fence



A Geo-fence can be created for an area specified.

The Geo-fence will be displayed on the Map tab. Dog alerts for the Geo-fence are turned on by default and a notification will appear when dogs exit and enter the Geo-fence.

- The Geo-fence alerts can be turned on and off in the Settings.

### Geo-fence Info

The info button displays more information on setting up the Geo-fence.

### Saving a Geo-fence

Long press the map to create a Geo-fence point. Geo-fence points must be created in clockwise order. Geo-fence points cannot intersect. A valid Geo-fence is displayed in green. An invalid Geo-fence is displayed in red and cannot be saved.

Once a valid Geo-fence is created, use the save button to save the Geo-fence to the map. Geo-fence points can be edited before saving. Hold and drag the Geo-fence points to edit its location.

## App Settings

### Screen Saver

- The phone screen turns off when covered or in a pocket and turns on when viewed.
- On Android devices, the screen will turn off when the proximity sensor is covered and turns on when the sensor is exposed.
- Turn this feature on and off using the On/Off button.

### Shake Control

- Shake your phone to jump between dogs or the main tabs.
- Select between tabs, dogs and no action.

### Volume Button Control

- Use the volume buttons to jump between dogs or zoom in/out on the map.
- Select between zoom, dogs and no action.

### Distance Unit

- The distance is displayed on the main tabs, and device list.
- Select between meters and yards.

### Speed Unit

- Select between seconds and hours.

### GPS Data

- The GPS Data Limit sets how far back the tracks are displayed. If 2 minutes is selected, only the tracks up to 2 minutes will be displayed.
- Select between intervals in 1 to 10 minutes or unlimited.

### Tracking Only Mode

The Pathfinder comes equipped with standard 5/8" contact points that can be extended to 3/4" contact points, for use with dogs with long or thick coats. Use the included adjustment tool to remove the contact points and the contact point washers to extend the length of the contact points. Replace the standard contact points with the non-stimulation contacts to disable the e-collar hardware. Set the app to Tracking Only Mode while using the non-stimulation contacts for use where e-collar stimulation is not allowed. This feature can be used for AKC or UKC events where the GPS is permissible but the e-collar is not.

- A new history file will begin recording when the Tracking Only Mode is turned on.

### Offline Map Data Usage

Turn Offline Map Data on to use cellular data when available with Offline maps. Turn Offline Map Data off to restrict data usage and only display downloaded Offline Maps.

## Alarm Setting

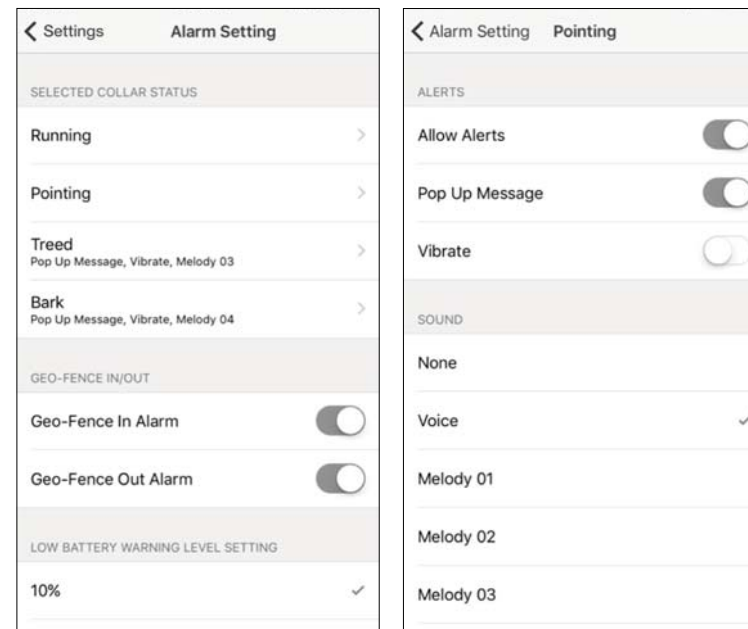

Settings for various alarms.

### Selected Collar Status

- Set the alert type for dog status changes.
- Separate alert types can be set for each dog status.
- Options for alerts are pop up, vibration and sound and can be turned on and off.
- Sound alerts include 5 melody options and voice.

### Allow Alerts

- Turning off Allow Alerts disables all alerts for the dog status.
- Pop Up Message displays a pop up notification alert.
- Vibrate is a phone vibration alert.
- Sound alerts include 5 melody options and voice. Turn off sound alerts by selecting none.

### Geo-fence In/Out

- Turn on/off alerts used with a saved Geo-fence.

### Low Battery Warning Level Setting

- The battery warning changes the device icon and displays a notification when the device battery reaches the battery percentage selected.

### Bluetooth Pairing

- Begin pairing mode on the phone to pair with the GPS Connector. Use the pairing mode to pair with a new or replacement GPS Connector.

### User Guide

- The User Guide goes over the main features of the Pathfinder.
- Review the User Guide when using the Pathfinder for the first time.

### General Maintenance Tips

- Be sure the rubber charging cap is securely in place on the GPS Connector/ Collar when in use.
- Carefully inspect the unit for any missing parts or damage to the casing after use. Damaged or broken casing may affect the waterproof guarantee on the unit.
- The antenna must be securely in place for maximum range.
- Charge the unit for 3.5 hours before storing for extended periods.
- Charge the unit fully once a month while in storage or before use.
- Do not keep the unit exposed to extreme climates.
- Dogtra may include updates and improvements to the Pathfinder app which can be downloaded through the App Store and Google Play.

## Troubleshooting Guide

If the unit is malfunctioning, please refer to the Troubleshooting Guide before sending it to Dogtra for service. If you have any questions or concerns, you may email them to [info@dogtra.com](mailto:info@dogtra.com) or call customer service at 1-888-811-9111.

### 1. Dog Does Not Respond to Stimulation

- Make sure the receiver/collar is turned on.
- Be sure the strap is on the dog tight enough so that both contact points are touching your dog's skin.
- The contact points may be too short for your dog's thick or long coat. To place an order for longer contact points, please contact Dogtra or a Dogtra dealer. If you are already using longer contact points, you may need to trim the hair on your dog's neck, so that both contact points are touching your dog's skin.
- The intensity level may be too low for your dog. Increase the stimulation until your dog responds, usually by a neck movement, head shaking, or looking over the shoulders. The response may be very subtle.

### 2. The LED indicator light comes on, but I do not feel any stimulation.

- Your tolerance may be higher than your dog's. You may need to try the unit on your fingertips where sensitivity is higher and/or increase the stimulation level. Be sure both contact points are touching both of your fingertips.
- The battery may be low. Check the LED indicator lights or the app for battery life.
- If you have a full charge, and you have done all of the above, your unit may need to be serviced. Please email us at [info@dogtra.com](mailto:info@dogtra.com), or call customer service at 1-888-811-9111.

### 3. The Pathfinder has no range, or the stimulation is weaker when my dog is farther away.

- Check to see if your fingers are touching the antenna, as the range may decrease substantially.
- Keep away objects from touching the GPS Connector antenna as the range may decrease substantially.
- The range indicated is for line-of-sight flat terrain. Heavy brush, trees, hills, buildings, and/or moisture will affect the range of your unit. For the best range, hold the GPS Connector vertically above your head, and/or try moving to higher ground.
- Any electrical conductors will affect the range, such as cars, chain-link dog runs, metal buildings, and radio towers. For the best results, operate away from these structures.

### 4. The GPS Connector/Collar is not holding a charge.

- The charging pin may be damaged. A metal pin inside the charging port should stand straight up and firm in the center. If the pin is wobbly, broken or missing, you will need to send the unit in for repair.

- The charging port must be clean prior to charging, clean out any dirt with a cotton swab and some rubbing alcohol. If your dog was in salt-water, be sure to rinse the GPS Collar and charging port with clean water.
- For Dogtra units over two years old from the purchase date, the batteries may need to be replaced. You can replace them yourself by contacting Dogtra for a replacement battery. Damages incurred to the unit due to improper battery installations are not covered under the warranty. Dogtra strongly recommends sending the unit in for inspection and repair.

#### **5. My dog has skin irritation.**

- This may be due to an improper fit or from wearing the collar too long. If your dog exhibits signs of skin irritation, consult with a veterinarian. Once your dog's skin returns to a normal condition, continue to use the collar and check your dog's neck each time you use the unit.

## **FCC Warning**

This device complies with part 15 of the FCC Rules. Operation is subject to the following two conditions: (1) This device may not cause harmful interference, and (2) this device must accept any interference received, including interference that may cause undesired operation.

This is a sensitive radio device. Any unauthorized changes or modifications to this device that are not expressly approved by Dogtra Co. will void the devices warranty, and might void user's authority to operate the equipment. So don't do it please.

#### **Radio Frequency Radiation Exposure**

This device is a mobile transmitter and receiver that uses an external antenna to send and receive low levels of radio frequency (RF) energy for data communications. The device emits RF energy below the published limits when operating in its maximum output power mode and when used with Dogtra Co. authorized accessories. To comply with RF exposure compliance requirements, the device should be installed and operated with a minimum of 0.2m between the device and your body. The device should not be used in other configurations.

This device must not be co-located or operated in conjunction with any other transmitter or antenna.

## **WARRANTY AND REPAIR INFORMATION**

#### **2-Year Limited Lifetime Warranty**

Dogtra Company provides the original purchaser with a 2-YEAR WARRANTY for the 175NCP, 180NCP, 200NCP Gold/C Series, 210NCP Series, 280NCP/C Series, 300M Series, 1400NCP Series, 1500NCP Series, 1600NCP Series, 1700NCP Series, 1800NC Series, 1900NCP/S Series, 2000T&B Series, 2200NCP Series, 2300NCP Series, 2500T&B Series, 3500NCP Series, SureStim Series, ARC, Combo, EDGE RT and the Pathfinder. The warranty begins from the date of purchase. For the first two years, coverage is for both Parts and Labor on warranty repair services.

Accessories such as chargers, splitter cables, antennas, straps, and batteries are covered for the first year only. After the first two years, the Limited Lifetime Warranty covers Parts only and does not cover Labor Fees and Accessories. All Shipping fees incurred, the cost of Accessories after the first year, and Labor fees associated with out of warranty repair work, are the customer's responsibility. Labor fees will be variable depending on the extent of the work required. The Limited Lifetime Warranty expires 5 years after a model is discontinued from production by Dogtra.

#### **To Qualify for the Dogtra Warranty**

All products must be registered and/or a proof of purchase is required to initiate repair work under warranty. To register your Dogtra product, log onto our website at [www.dogtra.com](http://www.dogtra.com), click on the warranty registration link, and fill out the required information. Registration must be completed within 30 days of purchase. If you do not have access to a computer, you can call our toll free number at 1-888-811-9111, and one of our customer service representatives will register the product for you. If you were unable to register your product within 30 days of purchase, we will accept all products for repair with a proof of purchase. We strongly recommend keeping the original receipt. If your product is not registered and a proof of purchase is not available at the time of service, Dogtra will estimate the age of the unit by the serial number. Serial number estimates can differ from the actual purchase date. A serial number estimate is the only method of determining an approximate date of purchase without product registration or a proof of purchase.

#### **Not Covered Under Warranty**

Dogtra DOES NOT offer warranty for products that have been bought secondhand or as a resold product.

Dogtra DOES NOT replace defective units or provide refunds for products purchased from us after 30 days from the date of purchase.

Dogtra DOES NOT cover the cost of shipping outside of the Continental United States. Issues of replacement and refunds on units purchased less than 30 days from an authorized dealer must be addressed to the dealer directly. If the products purchased from an authorized dealer are after 30 days from the date of purchase, please send the units to Dogtra for service and repair.

Dogtra DOES NOT cover the cost of repairs and replacements due to misuse by the owner or dog, improper maintenance, and/or lost units. Any water damage on the Water Resistant Transmitters of the 175NCP, 180NCP, 200NCP Series, 1400NCP Series, 1500NCP Series, and iQ Pet Series, and the Water Resistant Receivers of the RRS, RRD, and RR Deluxe, will not be covered. All replacement costs for either the transmitter or receiver will be the owner's responsibility.

The warranty is void if the unit has been altered or an unauthorized person has damaged the unit while attempting repair work. Battery replacement by the customer during the first year of the 2-year Limited Lifetime Warranty is not recommended.

If the customer chooses to replace the batteries, any damage to the unit during the change-out by the owner will void the warranty.  
The removal of serial numbers from any Dogtra products will void the warranty.  
Dogtra reserves the right to retain and discard any parts or accessories that have been found damaged upon replacement and repair.

**Procedure for Repair Work**

If the unit is malfunctioning, please refer to the “Troubleshooting Guide” in the Owner’s Manual and call customer service at 1-888-811-9111, for technical support, before sending it to Dogtra for Service.

The cost of shipping products under warranty back to Dogtra is the customer’s responsibility. Dogtra is not responsible for units damaged or lost in transition to Dogtra. Dogtra is not responsible for loss of training time or inconvenience while the unit is in for repair work. Dogtra does not provide loaner units or any form of compensation during the repair period.

A copy of the sales receipt showing the purchase date may be required before warranty work is initiated.

Please include a brief explanation outlining the problem and include your name, address, city/state/zip code, daytime phone number, evening phone number, and email address. Or you can visit our website at [www.dogtra.com](http://www.dogtra.com) for a service request form. If the repair costs are not covered under warranty, we will call you for payment information and authorization. For any questions concerning your Dogtra products, call us toll free at 1-888-811-9111, M-F 8:30AM - 4:00PM, Pacific Standard Time, or email us at [repair@dogtra.com](mailto:repair@dogtra.com) for specific repair inquiries.

**Send repair units to :**  
**Dogtra Company / Repairs**  
**22912 Lockness Avenue,**  
**Torrance, CA 90501**  
**U.S.A.**

The diagrams and representations in the manual may differ slightly from the actual product depending on the model type.